

4

3

2

1

D

D

C

C

B

B

A

A

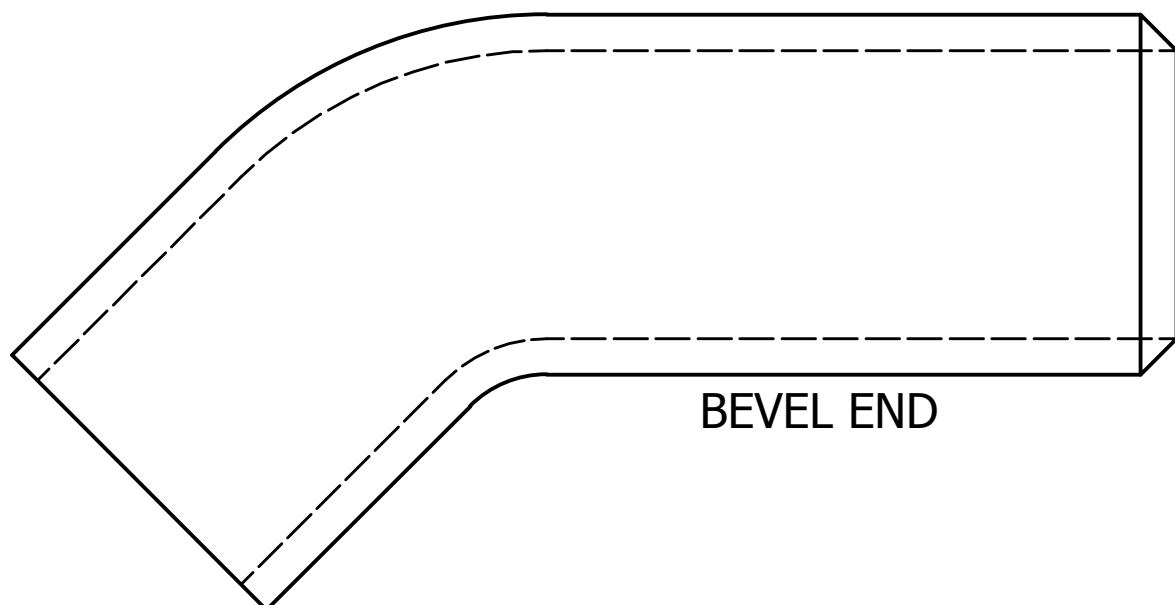

BEVEL END

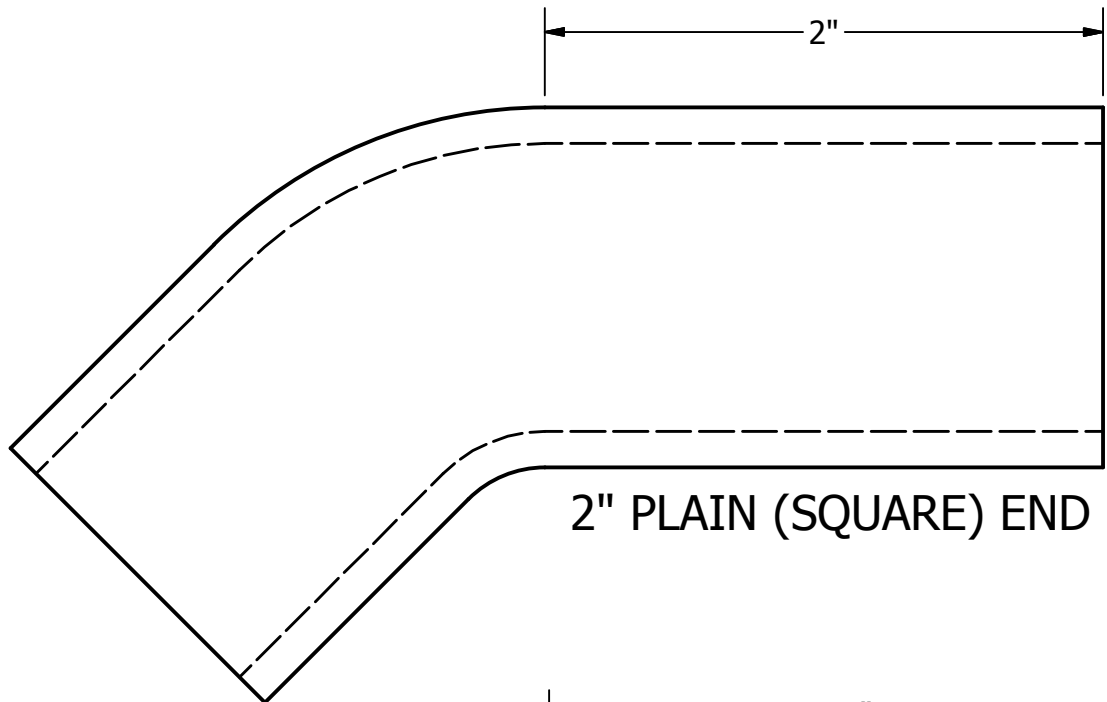

2" PLAIN (SQUARE) END

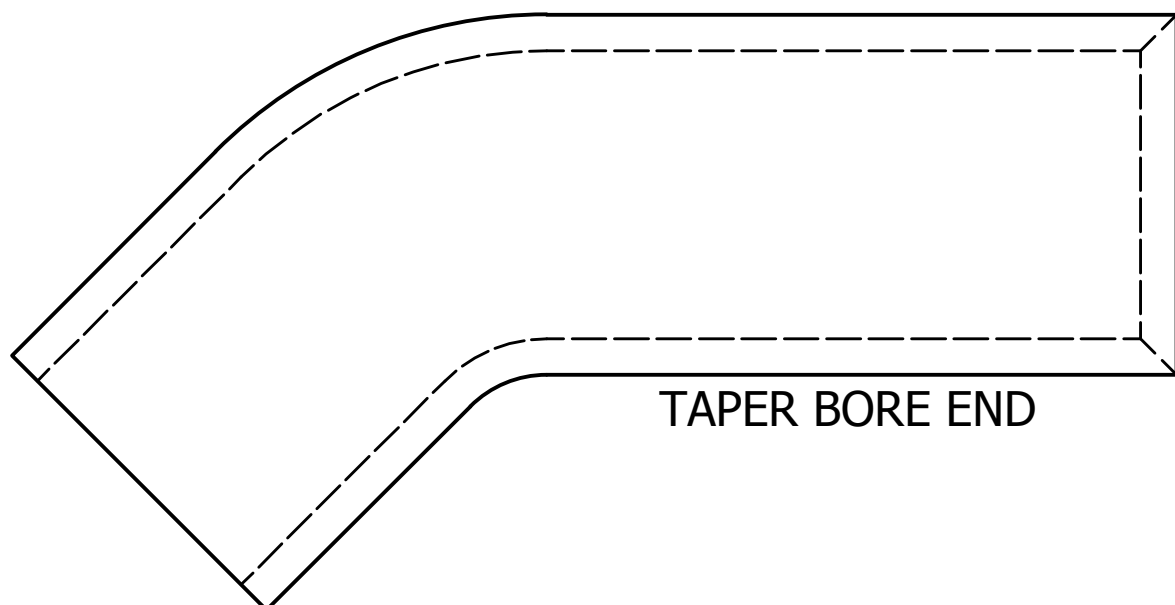

TAPER BORE END

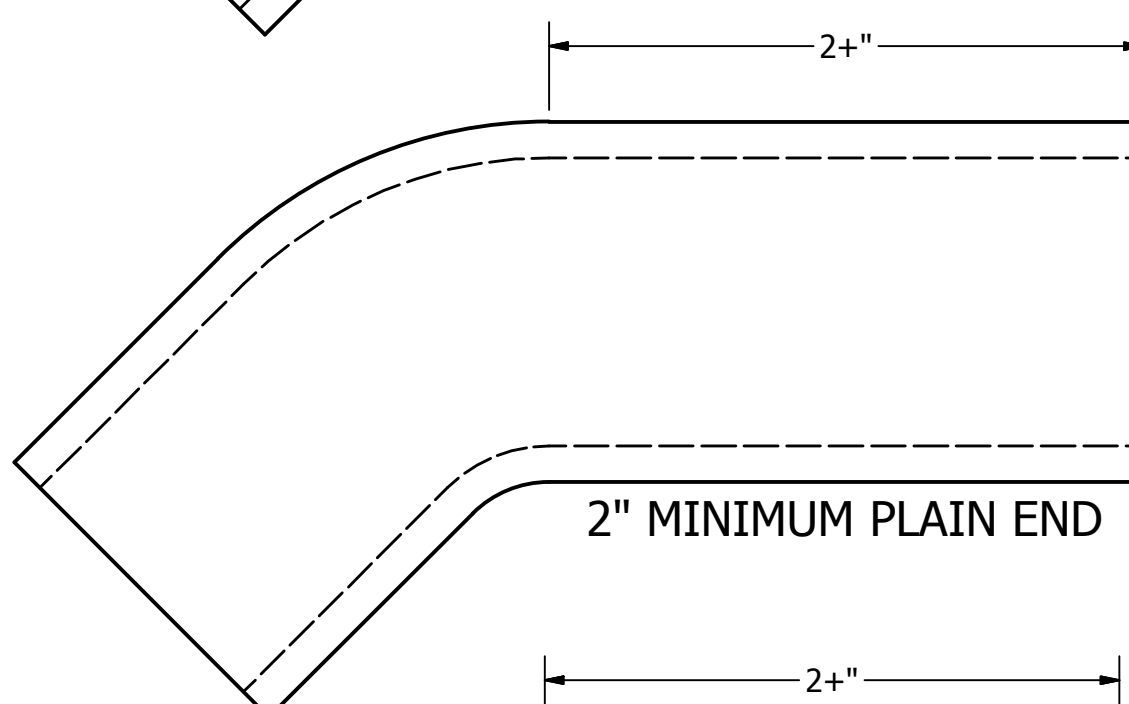

2" MINIMUM PLAIN END

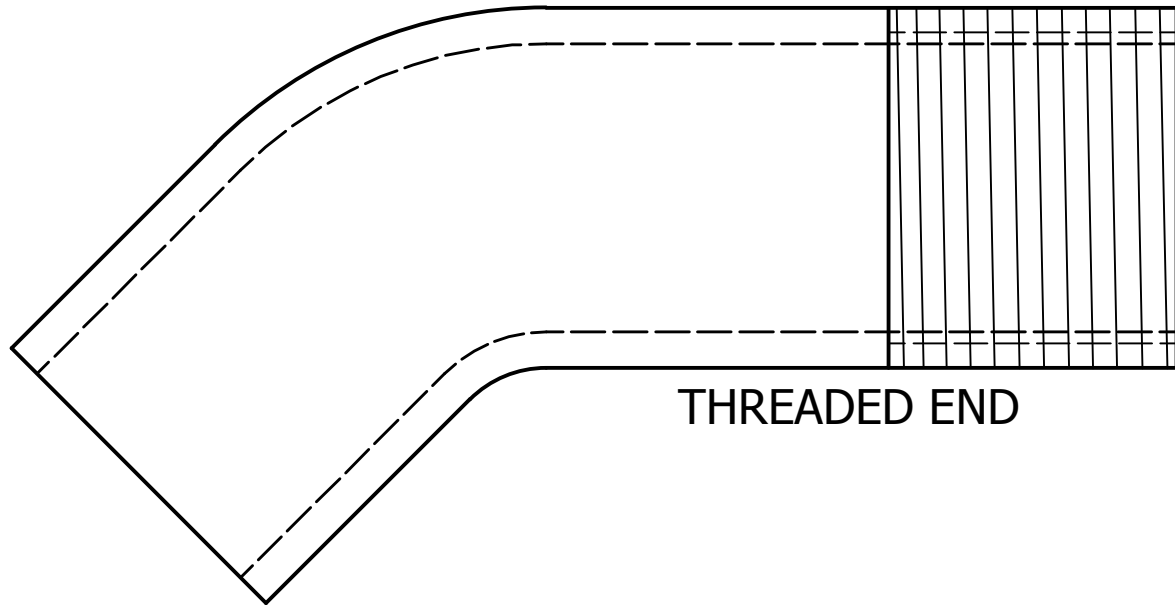

THREADED END

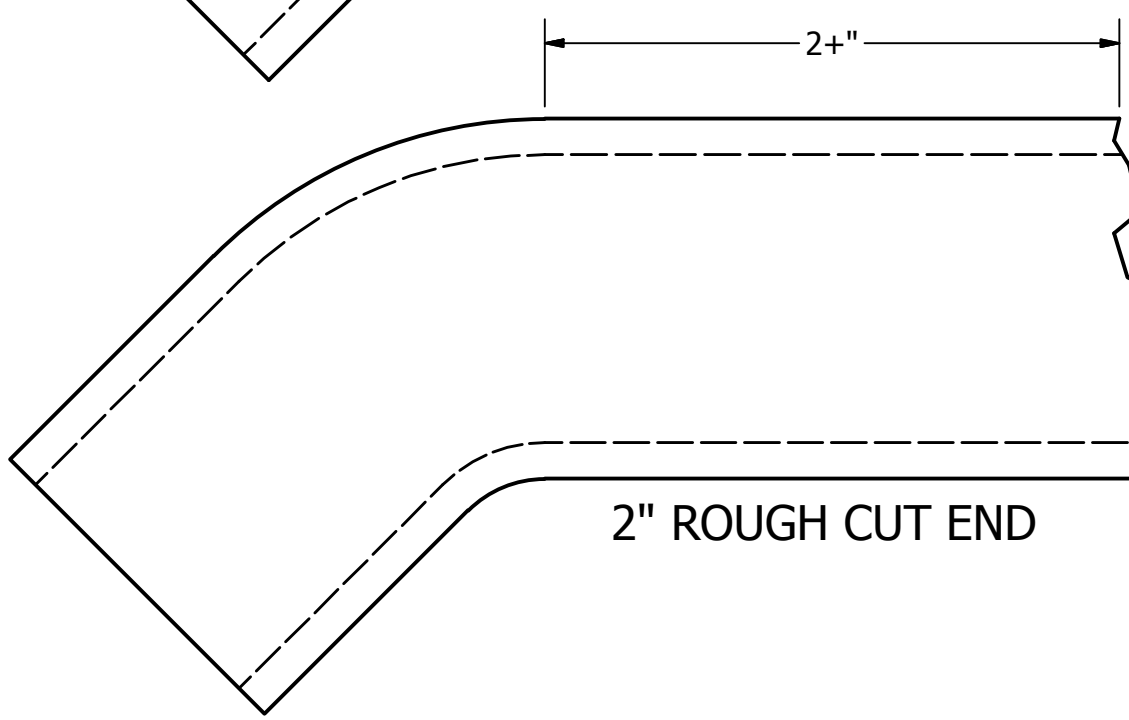

2" ROUGH CUT END

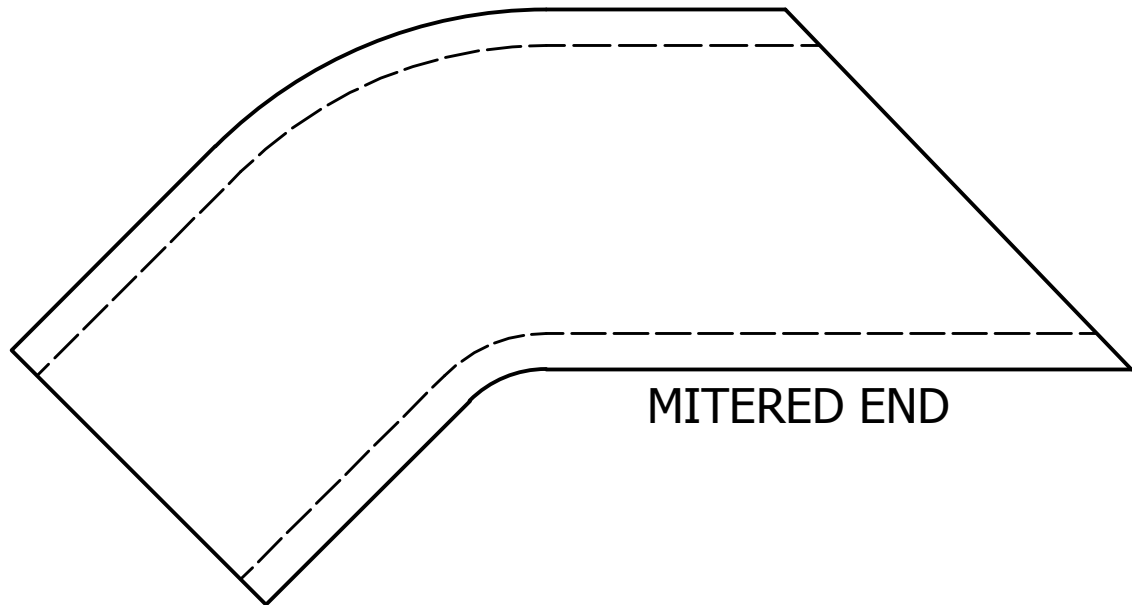

MITERED END

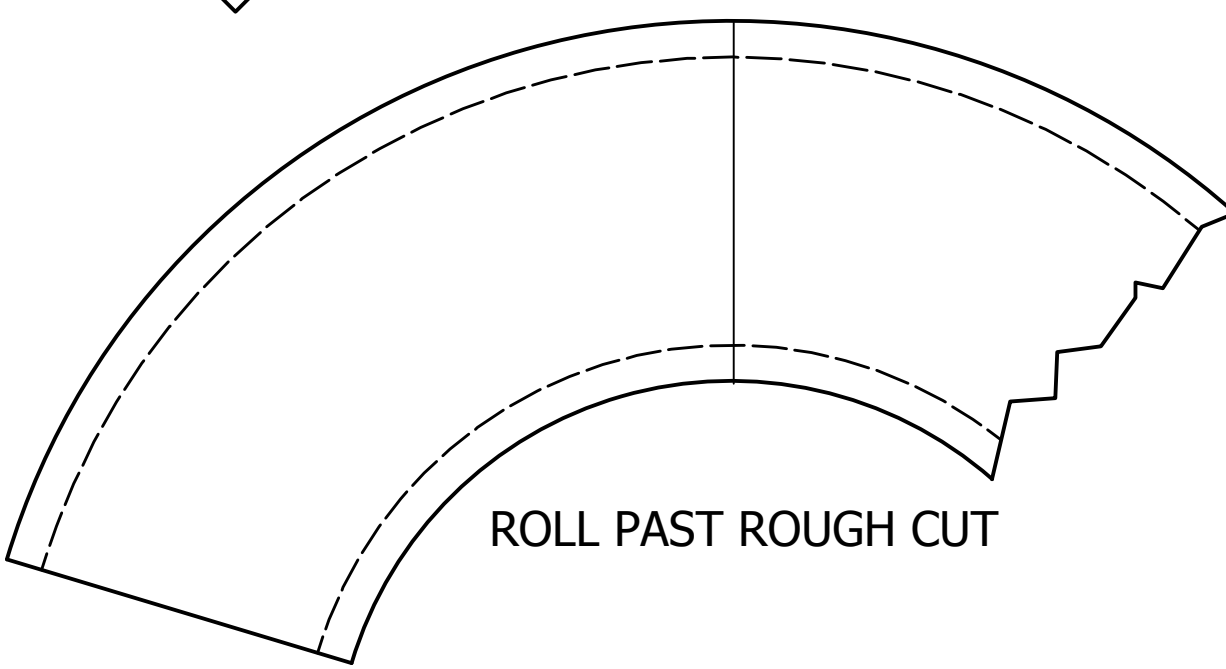

ROLL PAST ROUGH CUT

UNLESS OTHERWISE SPECIFIED
 DIMENSIONS ARE IN INCHES.
 TOLERANCES ARE:
 ANGLES: = ± 1°
 FRACTIONS: = ± 1/64
 DECIMALS: .XX = ± .01
 .XXX = ± .005

THIS DRAWING IS THE PROPERTY OF TULSA TUBE BENDING COMPANY. THE INFORMATION CONTAINED HEREIN IS CONFIDENTIAL, AND THE DISCLOSURE THEREOF WITHOUT THE PRIOR WRITTEN CONSENT OF TULSA TUBE BENDING COMPANY IS EXPRESSLY FORBIDDEN. THE INFORMATION CONTAINED MAY BE THE SUBJECT OF PENDING OR CONTEMPLATED PATENTS AND IS FURNISHED WITHOUT PREJUDICE TO THE PATENT RIGHTS OF TULSA TUBE BENDING COMPANY. THIS DRAWING IS TO BE USED ONLY FOR THE PURPOSE FOR WHICH IT WAS LOANED, RETURNED UPON REQUEST, AND IS NOT TO BE COPIED OR REPRODUCED IN ANY MANNER.

Tulsa Tube Bending Established 1959 COMPANY			
PART NUMBER:		COMMON END PREP	
DESCRIPTION:			
COMMENTS:			
PROJECT:	MATERIAL:	Generic	
SCALE:	DRAWN BY: jfranks	DATE:	SHEET: 1 OF 1